

150 Series Disc Feeder

Typical application of 150 Series:

- A. OC50 Controller
- B. 150 Disc Feeder
- C. Disc

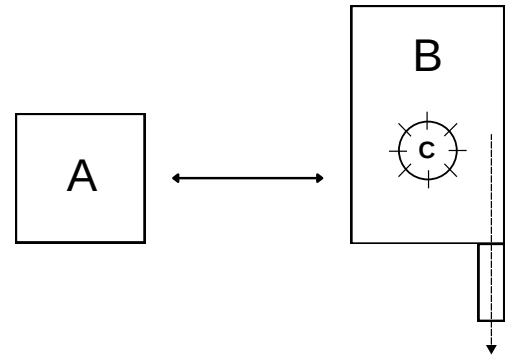

Description

Orbetron's 150 Series Feeder helps bridge the gap between the 100 and 200 Series Feeders. Like the entire disc feeder family, versatility is the key to its performance. The design offers a 150mm (6") in diameter feeding disc. The base feeder design is sized to feed low rate feeding applications of 0.6 to 500lb/hr (.03-226 kg/hr). All rates can vary based upon the density, flow-ability, and size of the material.

Alike the other Series Feeder sizes, the 150 Series smaller size allows for easy mounting to almost any process, holding unlimited possibilities! No auger or vibratory feeders can match The 150's capabilities, in terms of size, feeding capability, and repeatability.

Specifications

- 110/220 Vac single phase 50/60 hz
- Stepper Motor Drive
- Volumetric/Gravimetric Capable (Batch/Continuous)
- Quick Exchange Housing
- Dose Power to Pellet Materials
- Multiple Mounting Capabilities
- Separate Mounted Controls

OC50 Controller

- Separate Mounted Controls
- HMI Color Touchscreen
- PLC Control with I/O for Stepper, DC, or AC Motors

Design

- Standard disc sizes include 48, 24, & 12 holes per revolution. Special disc sizes are designed based upon your feeding needs
- 3D printing technology is utilized to design disc specifications
- High exchange and easy-clean capabilities

Options

- *External Alarm Audible & Light*
- *Spare Station for Easy Changeover*
- *Optional Agitation for Special Materials*
- *Continuous running software*
- *Extension Cable*
- *SS Hopper*
- *Small loader adapter*
- *Multi-component capability up to 4 units*



EZI-Dock optional